

Load Cell Central

1-800-LOADCEL

Stainless Steel Bellows Beam Load Cell

Model: HBBG

Ranges from 20 to 500 KG

The LCC-HBBG load cell is designed for harsh industrial applications such as the food, chemical, and pharmaceutical industries. The strain gauge area and electronic parts are covered by the stainless steel bellows to provide an IP68 protection class rating. When used with the Duramount 25 weighing assembly the HBBG is ideal for low capacity belt scales and hopper scales.



Capacities: 20, 30, 50, 100, 200, 350, & 500KG

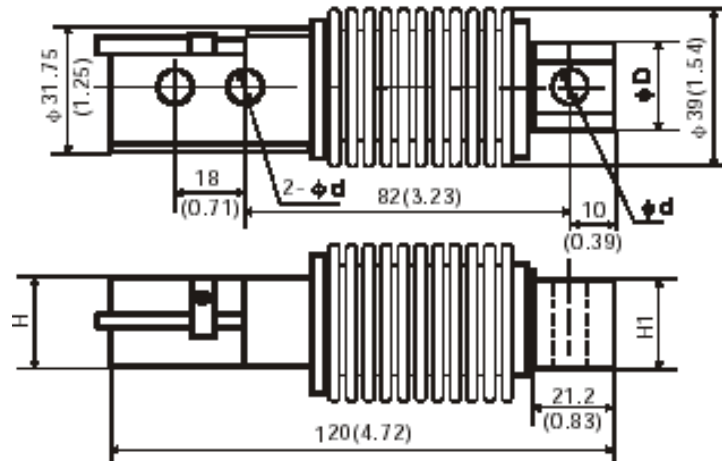

Dimensions in MM (inches)

| Capacity: KG | d | D | H1 | H |
|--------------|--------------|------------|------------|------------|
| 20 - 200 | 8.2 (0.32") | 23 (0.91") | 20 (0.79") | 20 (0.79") |
| 350-500 | 10.3 (0.41") | 24 (0.94") | 19 (0.75") | 20 (0.79") |

Electrical Connection:

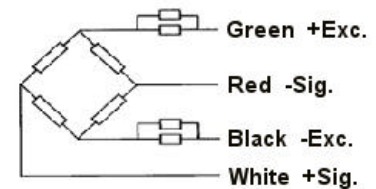

Specifications:

| | | | |
|-------------------------------|-------------------|-------------------------|-----------------|
| Combined Error: | 0.02% FS | Temp. Effect on Output: | 0.014% FS/10C |
| Rated Output: | 2.0 +/- 0.02 mV/V | Temp. Effect on Zero: | 0.017% FS/10C |
| Non-Linearity: | 0.017% FS | Compensated Temp.: | -10 to 40C |
| Non-Repeatability: | 0.01% FS | Operating Temp.: | -35 to 65C |
| Creep: | 0.02% FS/30min. | Recommended Excitation: | 10Vdc |
| Input Resistance: | 460 +/- 50 Ohms | Safe Overload: | 150% FS |
| Output Resistance: | 350 +/- 3.5 Ohms | Ultimate Overload: | 200% FS |
| Insulation Resistance Megohm: | >5,000 (50Vdc) | Cable Length: | 9.5' (3 meters) |
| Zero Balance: | 1% FS | Protection Class: | IP68 |

Load Cell Central
216 Main St. / PO Box 91
Monroeton, PA 18832
Web: www.800loadcel.com

Toll Free: 1-800-562-3235
Ph: 1-570-265-5015
Fax: 1-570-265-5148
Email: sales@800loadcel.com