

# Load Cell Central

1-800-LOADCEL



## Model OM-1 Bridgesensor

### Features

- Rugged, Compact and Fully Encapsulated
- Complete System - Just Add AC Power
- Ready to Use with Screwdriver Wiring
- Stable and Accurate

### Applications

- Weighing with Load Cells
- Long Term Structural Monitoring
- Process Control Pressure Transducers
- Low Frequency Strain Measurements

### Description

The Model OM-1 is a self contained, AC powered, signal conditioning module for bridge type instrumentation. It contains a precision differential instrumentation amplifier with filtered output and a highly regulated, low noise, adjustable output bridge excitation source. The unit is completely encapsulated for use in rugged environments.

### Transducer Excitation

Transducer bridge excitation is provided by an AC line powered, adjustable, well regulated, low noise power supply. The excitation voltage is adjusted by means of a molded-in potentiometer, which allows the output voltage to be varied from 4 to 15 Volts. The output ripple is extremely low and the line and load regulation are 0.05%.

The sense lines minimize variations in output voltage with changes in load current or lead resistance. It should be noted that if the sense feature is not being used, terminal 1 must be connected to terminal 2. Terminals 3 and 4 must be connected also. The supply will provide up to 150mA of output current. These features make the unit ideal for use with most common strain gage bridge circuits of 120, 350, and 500 Ohms.

The supply has short circuit protection to protect it against short term faults. The output recovers automatically from short circuit conditions once the short is removed.

B+ VOLTAGE vs LOAD CURRENT

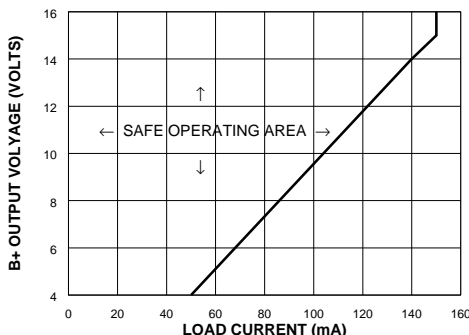

FIGURE 1. Bridge Supply - Safe Operation

### Safe Operation in the Unsafe Area

The curve (Figure 1) describes the region of safe operating output current at each voltage setting level. If excitation is desired at the 4 Volt level with 150mA, this can be accomplished by using a resistor of at least 2 Watts in size in series with the bridge. The right value resistor would drop 11 Volts allowing 4 Volts at 150mA across the bridge while minimizing internal heating of the Model OM-1. The + sense line would regulate the supply to the required 4 Volts. Normal operation of single bridges at 10 Volts and under 100mA (all 120, 350, and 500 Ohm bridges) can be accomplished within the safe operating area.

### Instrumentation Amplifier

The built-in amplifier is a true differential input, low noise, low drift, instrumentation amplifier. It has a high common mode rejection ratio (CMRR) and is provided with an output offset that is potentiometer adjustable. The minimum gain setting of the amplifier is 40 and the maximum gain using the built-in potentiometer is 250. The gain may be adjusted up to a maximum of 1,000 by means of an external resistor connected across terminals 12 and 13. The size of the external resistor can be calculated using the gain formula in the specifications. When doing this the coarse gain potentiometer should be turned fully clockwise. The fine gain pot can then be used for final gain adjustment. The output offset adjustment range is  $\pm 0.5V$ .

The amplifier can withstand input voltages up to 15 Volts without damage. The output of the amplifier is filtered to be 3 dB down at 3 Hz using a double pole Butterworth response filter to minimize the effects of high frequency electrical and physical noise on the system. The output of the amplifier is  $\pm 10$  Volts at 5mA making it compatible with modern data acquisition techniques and systems.

# OM-1 Bridgesensor

## Specifications

(Typical @ 25°C unless noted)

<b>Amplifier</b>	
Gain Range with external R	40 - 250 to 1,000
Gain Temperature Coefficient	200 ppm/°C
Gain Potentiometer Hysteresis	0.2% of span max.
Gain Equation <i>Note: G is the desired voltage gain in V/V</i>	$R_g = \frac{1}{\frac{G-1}{40\text{ k}\Omega} - \frac{1}{150\Omega}}$
Drift (RTI)	2 ±20/G μV/°C
Input Bias Current	±30 nA
<b>Input Impedance</b>	
Differential	3,000 megohms
Common Mode	6 megohms
<b>Output Noise (RTO)</b> at gain = 100 1 Hz to 100 Hz	
	120 μV RMS
<b>Common Mode Rejection</b>	
Gain = 40 (DC)	96 dB
Rated Output (2k load)	±10V
Common Mode Voltage	±6.5V
Output Impedance (DC)	0.01 ohms
Dynamic Response	0.3s to 0.1%
DC to -3 dB two pole Butterworth Filter	3 Hz
Max. Input Voltage	±15V
<b>Bridge Supply</b>	
Input	115 VAC ±10% 50 to 60 Hz (100, 220 & 230 VAC available)
Output Voltage	4 to 15 Volts
Output Current	5 to 150 mA
(see output voltage vs current curve)	
Load & Line Regulation 0.05% VOUT = 12V, IL = 5 to 100 mA	
Output Noise	0.5 mV RMS
Drift	200 ppm/°C max.
B+ Potentiometer Hysteresis	0.3% of output max.
Short Circuit Current	750 mA
Line Isolation	1,500 VDC
<b>Mechanical</b>	
Operating Temperature	0°C to 70°C
Storage Temperature	-25°C to +85°C
Weight	18 oz. (510 grams)
Size	3.75"L x 2.0"W x 2.87"H 9.53 x 5.1 x 7.62 (cm)

## Getting Started with the OM-1

### I. Hook Up Procedure

**A.** Connect the +out of your load cell to the +INPUT, pin 10.

**B.** Connect the -out of your load cell to the -INPUT, pin 11.

**Note:** If the ±SENSE are not used in your load cell application, the connections in step C & D need to be followed. If the ±SENSE are going to be used, do not jumper them as described in steps C & D.

**C.** Connect B+, pin 4, to the + excitation of your load cell and jumper the +SENSE, pin 3, to B+, pin 4.

**D.** Connect B-, pin 2, to the - excitation of your load cell and jumper the -SENSE, pin 1, to B-, pin 2.

**E.** Connect the VAC power supply to the AC input lines, pins 6 and 7.

### II. Turn On Procedure

**A.** Verify that the hook up procedure is complete.

**B.** Verify the correct AC voltage is applied to the OM-1; i.e. 100, 115, 220, 230.

**C.** Turn on the AC source supply to the OM-1.

**D.** Set the required EXCITATION supply voltage to the load cell by adjusting B+ ADJUST, Pot B

### III. Calibration Procedure for Zero Adjustment

**A.** Jumper the + and - input terminals, pins 10 and 11, together.

**B.** Connect a volt meter across the output, pins 8 and 9.

**C.** Adjust the OUTPUT OFFSET, Pot A, potentiometer for zero.

### IV. Full Scale Voltage Adjustment

**A.** Remove the jumper between the + and - input terminals and apply a known load to your load cell, in most cases it would be 100% of full scale.

**B.** Adjust the COARSE GAIN, Pot D, and FINE GAIN, Pot C, potentiometers for the desired FULL SCALE output.

**C.** Calibration is now complete. However, the user should recheck the ZERO & FULL SCALE output before continuing.

## Typical Bridge Application

Figure 2 shows a typical load cell application using a standard 350 Ohm bridge. Typical bridge output is 2 or 3mV/Volt of excitation. With the power supply excitation voltage at 10 Volts an output of 20 or 30mV from the bridge can be obtained. The common mode voltage of the bridge (the instrumentation amplifier input signal level) is 5 Volts. This is well within the 6.5 Volt common mode voltage range of the amplifier.

# OM-1 Bridgesensor

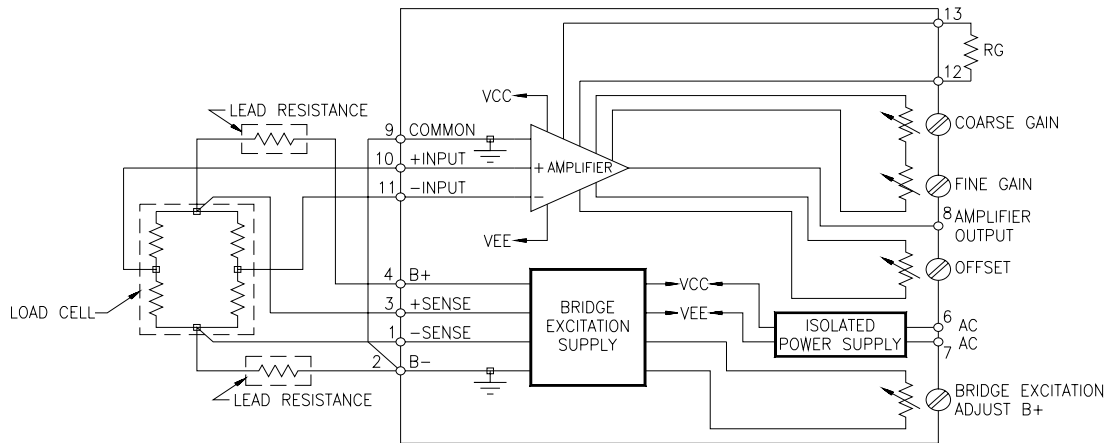

FIGURE 2. Typical load Cell Application

The gain must be set between 300 and 600 depending on the output of the bridge. The built-in potentiometer set to a gain of 200 would achieve an output voltage of 4 to 6 Volts. For a higher level output an external resistor must be used. The value of that resistor can be calculated using the gain formula. It can also be arrived at empirically using a calibrated input signal equal to the maximum input signal expected and a resistance substitution box to adjust the gain until the desired full scale output voltage is achieved.

Assuming a standard 350 Ohm bridge is used, the current required from the excitation supply (set at 10 Volts) would be 28.6mA. If the leads were long enough to have 10 Ohms of internal resistance there would be a drop of over 0.25 Volts in both the plus and common side of the bridge. To eliminate this potential error (especially where the current might vary during the course of a measurement) the sense lines are connected to measure and regulate the voltage right at the bridge rather than at the output of the supply thereby eliminating this potential source of error. The decision of whether to use the sense leads or not depends entirely on the lead length, its resistance and the effect of that error on the measurement.

## Application Suggestions

The Model OM-1 is designed to eliminate many of the ordinary problems associated with bridge type measurements. Since the whole system is in one case the common problem of ground loops or circulating currents caused by poor wiring practices is eliminated. It is recommended that lead lengths be kept to a minimum. The use of shielded twisted pairs for the input leads is recommended for most applications.

To minimize self heating errors the use of minimum excitation power is suggested as is sufficient heatsinking of the transducer wherever possible. For optimum stability a one hour warm-up is recommended. Avoid large temperature changes or stray magnetic fields.

The output leads should be kept short to minimize capacitive loading on the output of the amplifier. The Model OM-1 Bridgesensor is ready to wire into your system, have power applied, and to start making measurements for you.

## Mechanical Specifications

Specifically designed for rugged field use the Model OM-1 is completely encapsulated in epoxy using a vacuum potting system to insure a complete seal against corrosive environments. It is similarly protected against shock and vibration and will provide years of reliable and accurate operation.

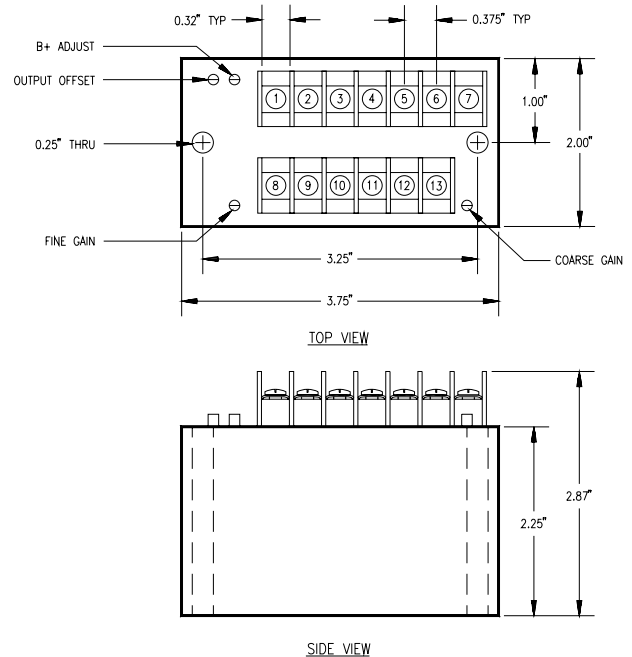

FIGURE 3

Terminal Strip Assignments			
Screw Terminal	Function	Screw Terminal	Function
1	-SENSE	8	OUTPUT
2	B-	9	AMPLIFIER CMN
3	+SENSE	10	+INPUT
4	B+	11	-INPUT
5	NOT USED	12	EXT. GAIN
6	AC	13	EXT. GAIN
7	AC		