

MODEL OM-25 BRIDGESENSOR



Description:

The OM-25 is a DIN Rail mount, self-contained DC powered module designed for load cell, strain gage, or single ended use. The OM-25 contains a precision instrumentation amplifier, filtered output and a built-in 10V excitation supply capable of driving a 350 ohm bridge. The 0 to 30mV input range makes it compatible with most strain gage based load cell or pressure transducer outputs. The OM-25 provides an output of 0 to 10Vdc. Connections are made via easily accessible screw clamp terminal blocks. Zero and Span adjustment potentiometers are located externally as well for easy access.

Features:

- Low Cost
- Din Rail Mount
- Load Cell or Single Ended Application
- 0-10V

Amplifier	
Gain Adjustment Range Input for 10V Output	333 to 1000 10mV to 30mV
Linearity: 0 to 10V Out	±0.01%
Temperature Coefficient	0.05% / °C
Input Offset Voltage Temperature Coefficient	±70µV 0.7µV / °C
Common Mode Voltage	0 to +5 Volts
Common Mode Rejection - DC	100 dB
Input Noise 0.1Hz to 10Hz	0.3µV pp Typ
Output	
Output Range	0V to +10V
Load Current	5mA Max
Frequency Response 2 Pole Filter	DC to 10Hz
Total RMS Gain Temperature Coefficient	0.007% / °C

Bridge Supply	
Fixed Output	+10V ±1.5%
Temperature Coefficient	0.05% / °C
Load Current	30mA Max
Power Requirements	
Voltage	18 to 26 VDC
Input Current (1 - 350 Ohm Bridge)	40 mA
Environment	
Operating Temperature	0°C to +55°C
Storage Temperature	-40°C to +80°C
Size	
Size (Not including Universal Foot for standard DIN EN Rails)	1.65"H x 1.06"W x 3.78"L (42 x 27 x 96mm)
Weight	3 oz. (85g)
Agency Approval	
UL, CE	UL508, UL1604, CE Pending

Load Cell Central
1-800-LOADCELL

Load Cell Central • 216 Main St. • Monroeton, PA 18832
Toll Free: 1-800-562-3235 • Fax: 1-570-265-5148

MODEL OM-25 BRIDGESENSOR

FULL BRIDGE CONNECTION

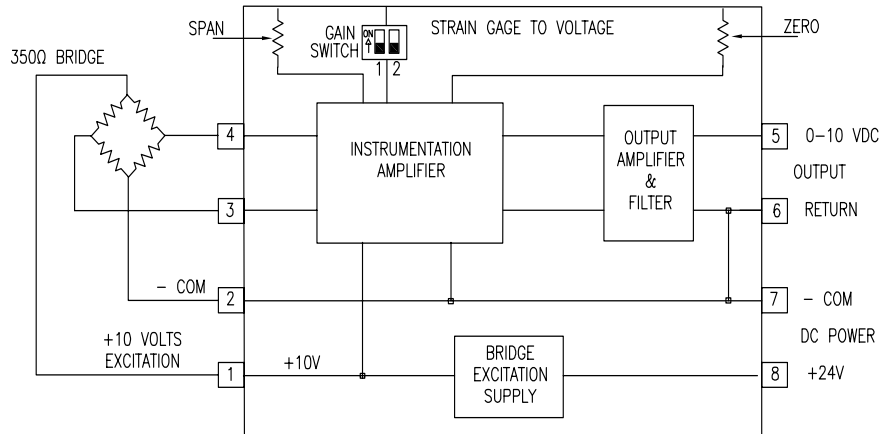

SINGLE ENDED

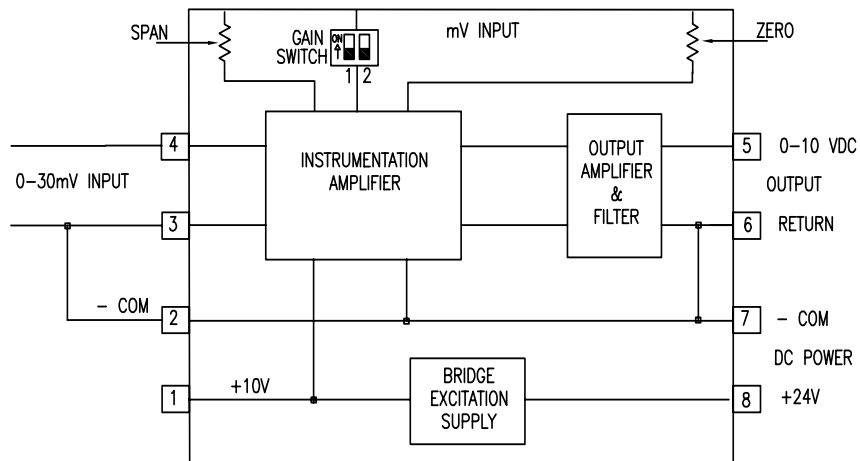

Getting Started with the Model OM-25

1. Hook Up Procedure

- Connect the +out of the load cell to the +INPUT, pin 3.
- Connect the -out of the load cell to the -INPUT, pin 4.
- Connect the +excitation of the load cell to +EXCITATION, pin 1.
- Connect the -excitation of the load cell to -EXCITATION, pin 2.
- Connect the +24 VDC power supply to +24V, pin 8 and COM, pin 7.

2. Turn on Procedure

- Verify that the hook up procedure is complete.
- Turn on the +24 VDC power source connected to the OM-25.

3. Calibration Procedure

- Jumper the +INPUT and the -INPUT terminals, pins 3 and 4, together.
- Check the Gain Switch Table, and set SW1-1 and SW1-2 to the expected full scale output of the load cell.

- Connect a voltmeter across the output, pins 5 and 6.
- Adjust the Zero Adjustment potentiometer for the desired output.
- Remove the jumper from the +INPUT and -INPUT terminals.
- With no load on the load cell, readjust the zero output.
- Apply a known load to the load cell; in most cases it would be 100% of full scale.
- Adjust the SPAN ADJUSTMENT potentiometer for the desired full scale output.
- Repeat steps F thru H until the desired settings are obtained.

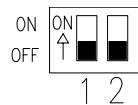

SW1-1	SW1-2	FULL SCALE LOAD CELL INPUT
OFF	OFF	30 mV
ON	OFF	20 mV
ON	ON	10 mV

Load Cell Central
1-800-LOADCEL

Load Cell Central • 216 Main St. • Monroeton, PA 18832
Toll Free: 1-800-562-3235 • Fax: 1-570-265-5148

MODEL OM-25 BRIDGESENSOR

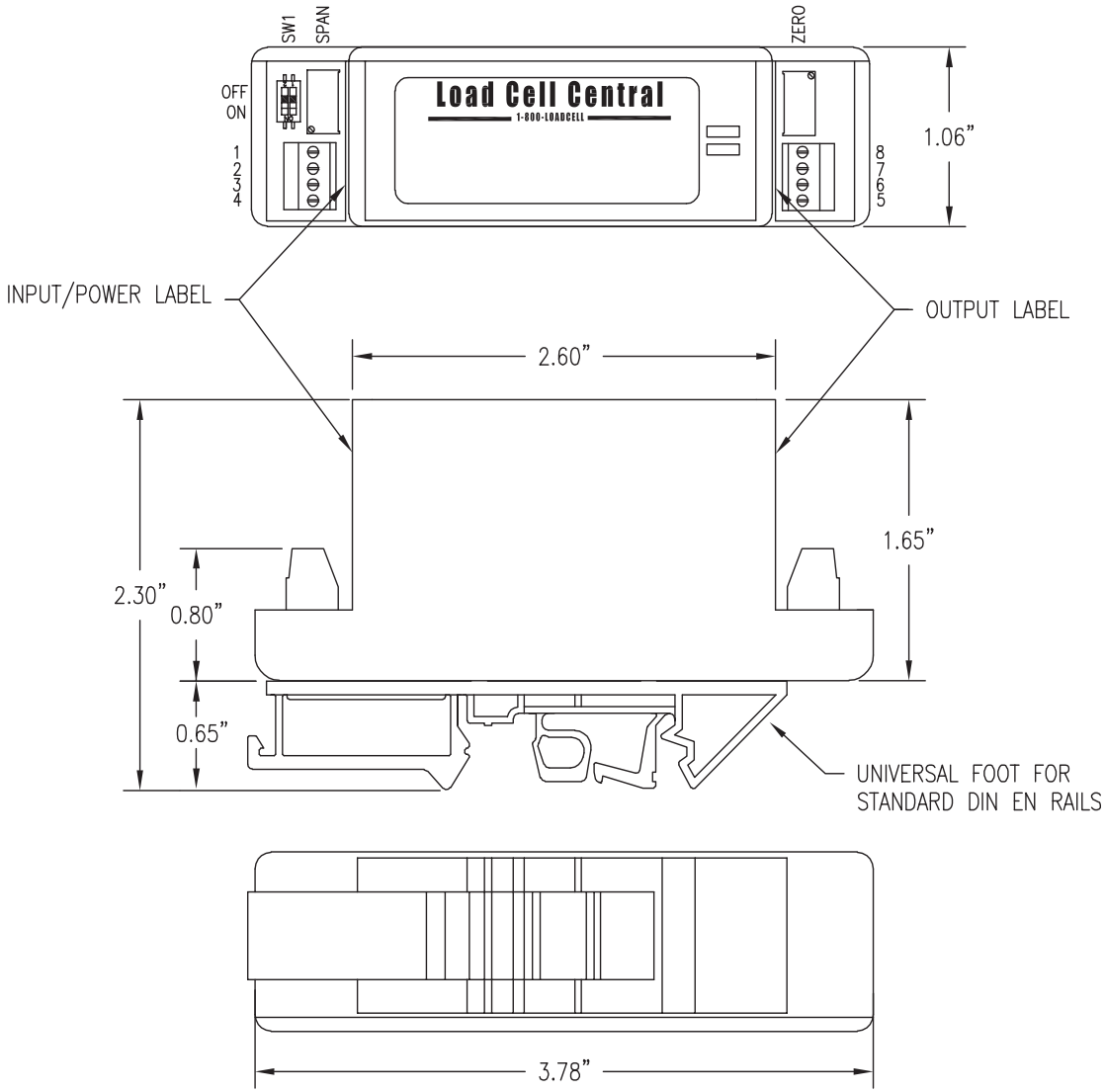

Mechanical tolerances unless otherwise noted:

X.XX dimensions ± 0.020 inches
 X.XXX dimensions ± 0.005 inches

TERMINAL	FUNCTION
SW1-1, SW1-2	GAIN SWITCHES
SPAN	SPAN ADJUSTMENT
1	+EXCITATION
2	- EXCITATION
3	-INPUT
4	+ INPUT

TERMINAL	FUNCTION
5	+ OUTPUT
6	COM
7	COM
8	+24V
ZERO	ZERO ADJUSTMENT

Load Cell Central
1-800-LOADCEL

Load Cell Central • 216 Main St. • Monroeton, PA 18832
 Toll Free: 1-800-562-3235 • Fax: 1-570-265-5148