

# Load Cell Central

1-800-LOADCEL

## UMC-555 Digital Scale Indicator



Measurement  
Canada  
Approved

The UMC555 is a rugged industrial digital weight indicator designed for simple operation in a variety of applications. The UMC555 is available in a mild steel painted enclosure with a tilt stand base panel mounting brackets, or an uncased version for custom applications. Primary applications include platform scales, tank scales, truck scales, and railroad track scales.

The UMC555 also offers BCD output (UMC2000 compatible), RFI/EMI shielded, (12-bit) optically-isolated 4-20 mA or 0-10VDC analog output, and versatile battery operation.

### Applications

- Mechanical conversions
- Straight weighing

### Standard Features

- Four-button operation
- Mild steel NEMA 1 enclosure
- Tilt stand base
- Front-panel calibration
- Zero, Net/Gross, Tare and Print keys

### Options/Accessories

- 19576 ..... BCD output, external, 115 VAC
- 55458 ..... BCD output, external, 230 VAC
- 19578 ..... Analog output, 0-10/4-20 mA, 115 VAC
- 55469 ..... Analog output, 0-10/4-20 mA, 230 VAC
- 19577 ..... Battery pack, 115/230 VAC
- 56116 ..... RS-485 serial expander
- 16815 ..... Technical manual
- 16819 ..... Additional operating manual

### UMC555 PART NUMBERING GUIDE

UMC555	( )	( )	( )	( )
ENCLOSURE				
A = Mild steel painted enclosure with tilt stand				
B = Mild steel painted enclosure with panel mount brackets				
C = Uncased board set				
INPUT POWER				
A = 115 VAC, 60 Hz				
B = 230 VAC, 50 Hz				
C = 12 VDC (external output)				
OPTIONS				
A = Standard				
B = Battery pack with charger				
C = Parallel BCD				
D = Analog output 0-10 VDC; analog output 4-20 mA				
LOAD CELL TERMINATION				
A = Standard unit				
C = RFI - shielded				

### PART # DESCRIPTION (PART NUMBERING CHART ON BACK OF PAGE)

- 115 VAC**
- 19189 ..... UMC555AAAC, mild steel enclosure w/tilt stand, 115 VAC 60 Hz, standard options, RFI shielded
  - 61959 ..... UMC555BAAC, mild steel enclosure w/panel mount brackets, 115 VAC 60 Hz, standard, RFI shielded
  - 61178 ..... UMC555CAAC, uncased board set, 115 VAC 60 Hz, standard, RFI shielded
  - 61224 ..... UMC555AACC, mild steel enclosure w/tilt stand, 115 VAC 60 Hz, parallel BCD, RFI shielded
  - 61237 ..... UMC555AADC, mild steel enclosure w/tilt stand, 115 VAC 60 Hz, Analog output 0-10 VDC; Analog output 4-20 mA, RFI shielded
  - 62018 ..... UMC555BADC, mild steel enclosure w/panel mount brackets, 115 VAC 60 Hz, Analog output 0-10 VDC; Analog output 4-20 mA, RFI shielded
  - 61869 ..... UMC555AAAC-35, mild steel enclosure w/tilt stand, 115 VAC 60 Hz, standard options, RFI shielded w/internal BCD
  - 64572 ..... UMC555BAAC-35, mild steel enclosure w/panel mount brackets, 115 VAC 60 Hz, standard, RFI shielded w/internal BCD
- 12 VDC (EXTERNAL INPUT)**
- 61363 ..... UMC555CCAC, uncased board set, 12 VDC, standard, RFI shielded
  - 62269 ..... UMC555BCAC, mild steel enclosure w/panel mount brackets, 12 VDC, standard, RFI shielded
- 230 VAC**
- 61279 ..... UMC555ABAC, mild steel enclosure w/tilt stand, 230 VAC 50 Hz, standard, RFI shielded
  - 61290 ..... UMC555ABBC, mild steel enclosure w/tilt stand, 230 VAC 50 Hz, battery pack w/charger, RFI shielded

Load Cell Central  
P. O. Box 91 / 216 Main St.  
Monroeton, PA 18832  
Toll Free: 1-800-LOADCEL / 1-800-562-3235

Phone: 1-570-265-5015  
Fax: 1-570-265-5148  
Email: salesam@800loadcel.com  
Web: www.800loadcel.com

# Load Cell Central

1-800-LOADCEL

## UMC555

## Specifications

**LOAD CELL EXCITATION:**

10 VDC, fixed, short-circuit proof

**LOAD CELL CURRENT:**

240 mA maximum (8 350Ω load cells)

**ANALOG SIGNAL INPUT RANGE:**

0.7 mV/V - 2.0 mV/V "high span"

1.7 mV/V - 3.2 mV/V "low span"

**CONVERSION RATE AT FULL SCALE:**

10 updates per second, no averaging

**RESOLUTION:**

10,000 displayed graduations

80,000 internal graduations

**DISPLAY:**

6-digit, 0.6" (15.2mm) red Light Emitting Diode (LED) Display

**LB/KG SWITCHING:**

Via customer supplied switch, with conversion for weight, tare values

**FRONT-PANEL CONTROL SWITCHES:**

Zero, Gross/Net, Tare, Print

**FRONT-PANEL ANNUNCIATORS:**

Center Zero, Net, lb, kg, Motion (Red bar LEDs)

**SERIAL OUTPUT:**

Port 1: Full duplex RS-232, 20 mA current loop (optional RS-485/422)

Port 2: Simplex RS-232, 20 mA current loop

**WEIGHT AVERAGING:**

10 updates per second fixed

**MOTION BAND:**

Selectable: Off, ±1, ±3 graduations, 1 second delay

**POWER INPUT:**

115/230 VAC, 50/60 Hz, or external DC

**POWER CONSUMPTION:**

15 watts

**OPERATING TEMPERATURE:**

14°F to 104°F (-10°C to 40°C)

**RATING/MATERIAL:**

Mild steel, NEMA 1 general purpose, tilt stand base standard

**WEIGHT:**

Approximately 5.5 lb (2.5 kg)

**APPROVALS:**

NTEP certified, CC# 00-005

Measurement Canada approved, MAL-SWA-4408 rev. 4

**WARRANTY:**

Two year warranty

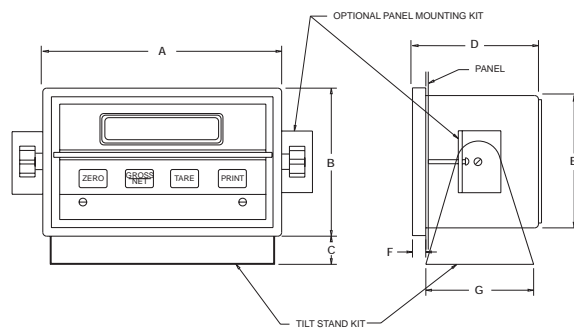

**DIMENSIONS**

A = 7.75" (196.8mm)	D = 4.09" (103.9mm)
B = 4.81" (122.2mm)	E = 4.31" (109.5mm)
C = 0.92" (23.4mm)	F = 0.43" (10.9mm)
or 2.06" (52.3mm)	G = 3.50" (88.9mm)

Load Cell Central  
P. O. Box 91 / 216 Main St.  
Monroeton, PA 18832  
Toll Free: 1-800-LOADCEL / 1-800-562-3235

Phone: 1-570-265-5015  
Fax: 1-570-265-5148  
Email: salesam@800loadcel.com  
Web: www.800loadcel.com