



OM - 2

DESCRIPTION

The OM-2 bridge sensor is a self contained, AC powered, signal conditioning module for bridge type instrumentation. It contains a precision differential instrumentation amplifier with filtered output and a highly regulated, low noise, adjustable output bridge excitation source. The unit is completely encapsulated for use in rugged environments. The output filter cutoff frequency is 2000Hz and may be lowered by adding two external capacitors.

FEATURES

- ◆ 2 kHz Frequency Response
- ◆ Rugged, Compact And Fully Encapsulated
- ◆ Complete System-just Add AC Power
- ◆ Ready To Use With Screwdriver Wiring
- ◆ Stable and Accurate

APPLICATIONS

- ◆ Weighing With Load Cells
- ◆ Long Term Structural Monitoring
- ◆ Process Control Pressure Transducers
- ◆ Temperature Controls Using Thermocouples
- ◆ Strain Measurements

SIMPLIFIED BLOCK DIAGRAM

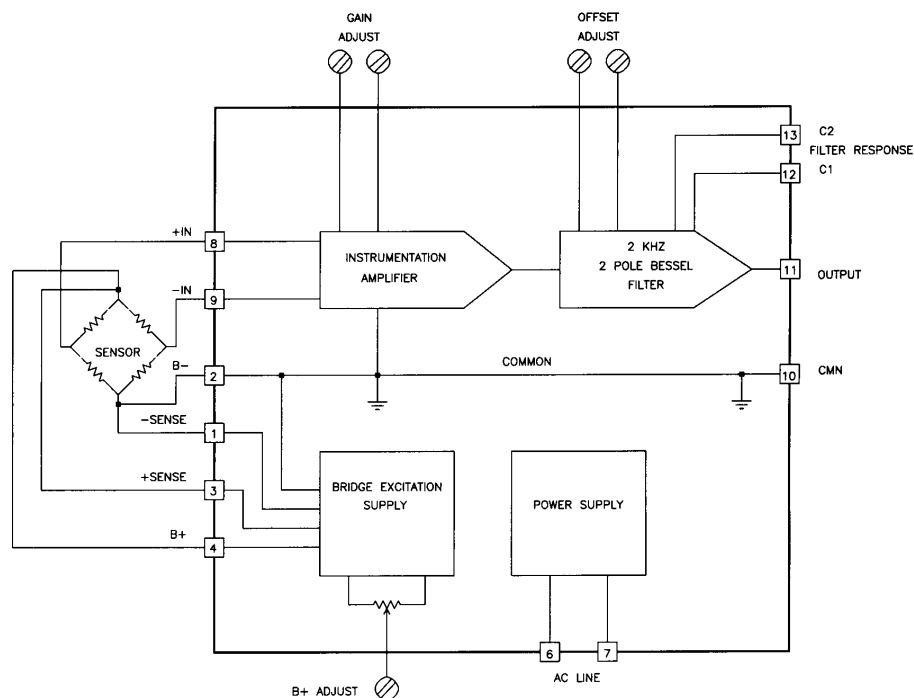

TRANSDUCER EXCITATION

Transducer bridge excitation is provided by an AC line powered, adjustable, well regulated, low noise power supply. The excitation voltage is adjustable by means of a molded-in potentiometer which allows the output voltage to be varied from 4 to 15 Volts. The output ripple is extremely low and the line and load regulation are 0.05%.

The sense lines minimize variations in output voltage with changes in load current or lead resistance. It should be noted that if the sense feature is not being used, terminal 1 must be connected to terminal 2. Terminals 3 and 4 must be connected also.

The supply will provide up to 120 mA of output current. These features make the unit ideal for most common strain gage bridge circuits of 120, 350, and 500 Ohms. The supply has short circuit protection to protect it against short term faults. The output recovers automatically from short circuit conditions once the short is removed.

B+ VOLTAGE vs LOAD CURRENT

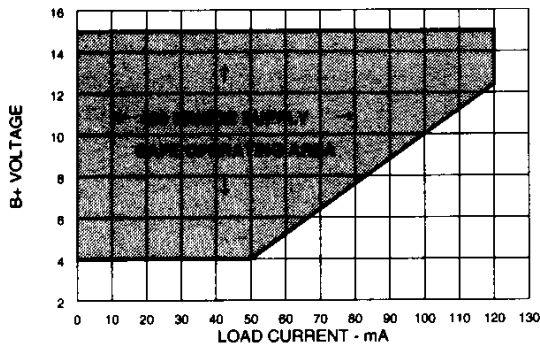

FIGURE 2. Safe Operating Curve

SAFE OPERATION IN THE UNSAFE AREA

The above curve (Figure 2) describes the region of safe operating output current at each voltage setting level. If excitation is desired at the 4 Volt level with 120mA, this can be accomplished by using a resistor of at least 2 watts in size in series with the bridge. The right value resistor would drop 11 Volts allowing 4 Volts at 120mA across the bridge while minimizing internal heating of the OM-2. The + sense line would regulate the supply to the required 4 Volts. Normal operation of single bridges at 10 Volts and under 100mA (all 125, 350, and 500 Ohm bridges) can be accomplished within the safe operating area.

INSTRUMENTATION AMPLIFIER

The built-in amplifier is a true differential input, low noise, low drift, instrumentation amplifier. It has a high common mode rejection ratio (CMRR) and is provided with an output offset that is potentiometer adjustable. The minimum gain setting of the amplifier is 40 and the maximum gain is 250. The amplifier can withstand input voltages up to 15 Volts without damage. The output of the amplifier is filtered to be 3dB down at 2kHz using a double pole Bessel response filter. The output of the amplifier is 10 Volts at 5mA making it compatible with modern data acquisition techniques and systems. Capacitors may be added to terminals 10, 11, 12, and 13 to lower the filter cutoff frequency. This will reduce the OM-2 output noise and system noise where the high frequency response is not required.

TYPICAL BRIDGE APPLICATION

Figure 3 shows a typical bridge application using a standard 350 Ohm bridge. This could be a strain gage, load cell, pressure transducer, accelerometer, or other bridge based measurement.

Typical bridge output is 2 or 3 mV/Volt of excitation. With the power supply excitation voltage at 10 Volts an output of 20 to 30 mV from the bridge can be obtained. The common mode voltage of the bridge (the instrumentation amplifier input signal level) is 5 Volts. This is well within the 7.5 Volt common mode voltage range of the amplifier. The built-in potentiometer set to a gain of 200 would achieve an output voltage of 4 to 6 Volts.

Assuming a standard 350 Ohm bridge is used, the current required from the excitation supply (set at 10 Volts) would be 28.6mA. If the leads were long enough to have 10 Ohms of internal resistance there would be a drop of over 0.286 Volts in both the plus and common side of the bridge. To eliminate this potential error (especially where the current might vary during the course of a measurement) the sense lines are connected to measure and regulate the voltage right at the bridge rather than at the output of the supply. The decision to use the sense leads or not depends entirely on the lead length, its resistance, and the effect of that error on the measurement.

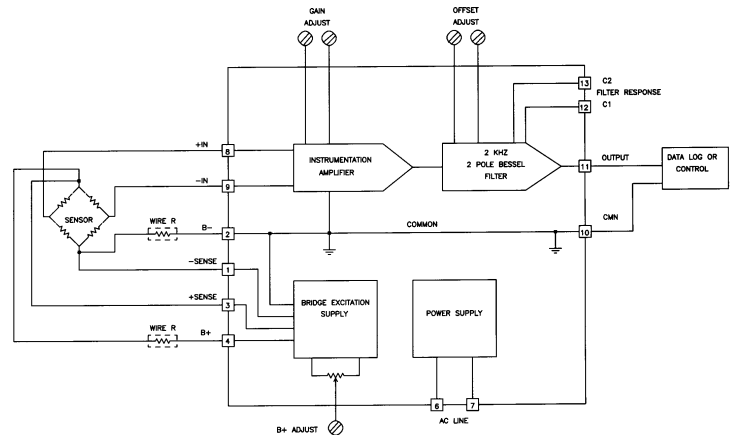

FIGURE 3. Typical Bridge Application

Getting Started with the OM-2

I. Hook Up Procedure

- A. Connect the +out of your load cell to the +INPUT, pin 8.
- B. Connect the -out of your load cell to the -INPUT, pin 9.
 Note: If the +/- SENSE are not used in you load cell application, the connections in step C & D need to be followed. If the +/-SENSE are going to be used, do not jumper them as described in steps C & D.
- C. Connect B+, pin 4, to the excitation of your load cell and jumper the +SENSE, pin 3, to B+, pin 4.
- D. Connect B+, pin 2, to the -excitation of your load cell and jumper the -SENSE, pin 1, to B-, pin 2.
- E. Connect the VAC power supply to the AC input lines, pins 6 and 7.

II. Turn On Procedure

- A. Verify that the hook up procedure is complete.
- B. Verify the correct AC voltage is applied to the OM-2; i.e. 100, 115, 220, 230.
- C. Turn on the AC source supply to the OM-2.
- D. Set the required EXCITATION supply voltage to the load cell by adjusting B+ ADJUST.

III. Calibration Procedure for Zero Voltage Adjustment

- A. Jumper the + and - input terminals, pins 8 and 9, together.
- B. Connect a volt meter across the output, pins 11 and 10.
- C. Adjust the COARSE OFFSET and the FINE OFFSET potentiometers for the desired zero voltage.

IV. Full Scale Voltage Adjustment

- A. Remove the jumper between the + and - input terminals and apply a known load to your load cell, in most cases it would be 100% of full scale.
- B. Adjust the COARSE GAIN and FINE GAIN potentiometers for the desired FULL SCALE output.
- C. Calibration is now complete. However, the user should recheck the ZERO & FULL SCALE voltage output before continuing.

SPECIFICATIONS

(Typical @ 25°C unless noted)

AMPLIFIER	
Gain Range	40 - 250
Gain Temperature Coefficient	200 ppm/°C
Gain Potentiometer Hysteresis	0.2% of span max.
Drift (RTI)	3 μ V/°C
Input Bias Current	\pm 30 nA
Input Impedance Differential Common Mode	3,000 megohms
Output Noise (RTO) at gain = 100 1 Hz to 2 kHz	2 mV P-P
Input Noise Line Frequencies	15 μ V P-P
Output Offset - Tare Range Drift	-5V to +2V \pm 0.2 mV/°C
Common Mode Rejection Gain = 40(DC - 60 Hz) Gain = 250(DC - 60 Hz)	90 dB 100 dB
Rated Output (2k load)	\pm 10V
Output Impedance DC to 2 kHz	0.01 ohms to 1 ohm
Dynamic Response DC to -3 dB two pole Bessel Filter	2 kHz
Common Mode Input Voltage	\pm 7.5V
BRIDGE SUPPLY	
Input	115 VAC \pm 10% 50 to 60 Hz (100, 220 & 230 VAC available)
Output Voltage	4 to 15 Volts
Output Current	120 mA
(see output voltage vs current curve)	
Load & Line Regulation 0.05% VOUT = 12V, IL = 0 to 100 mA	
Output Noise	0.5 mV RMS
Drift	200 ppm/°C max.
B+ Potentiometer Hysteresis	0.3% of output max.
Short Circuit Current	750 mA
Line Isolation	1,500 VDC
MECHANICAL	
Operating Temperature	0°C to 70°C
Storage Temperature	-25°C to +85°C
Weight	18 oz. (510 grams)
Size	3.75"L x 2.0"W x 2.87"H 9.53 x 5.1 x 7.62 (cm)

FILTER ROLL OFF FREQUENCY

The table in Figure 4 shows the values for C1 and C2 to set the 3 dB filter frequency. A printed circuit board is included for convenient mounting of the two capacitors. Use X7R ceramic or foil type capacitors.

FILTER FREQUENCY	C1 TO PIN 11	C2 TO PIN 10
2000 HERTZ	NONE	NONE
200 HERTZ	0.068 μ F	0.022 μ F
20 HERTZ	0.68 μ F	0.22 μ F
9.4 HERTZ	1.5 μ F	0.47 μ F

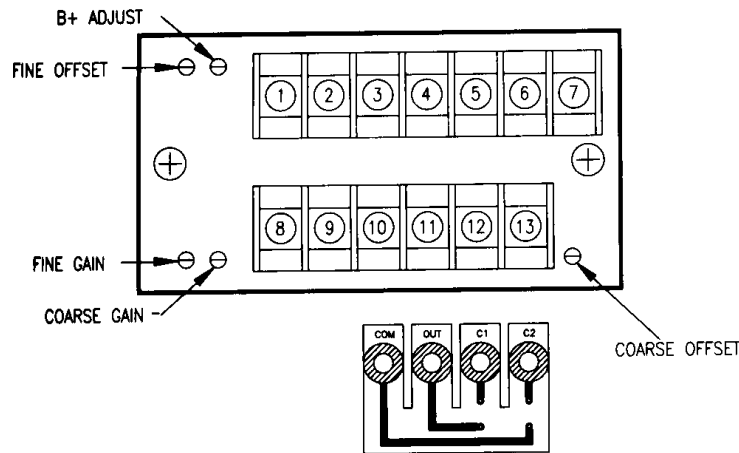

FIGURE 4. Filter Roll Off Frequency

APPLICATION SUGGESTIONS

The OM-2 is designed to eliminate many of the ordinary problems associated with bridge type measurements. Since the whole system is in one case the common problem of ground loops or circulating currents caused by poor wiring practices is eliminated. It is recommended that lead lengths be kept to a minimum. The use of shielded twisted pairs for the input leads is recommended for most applications. To minimize self heating errors the use of minimum excitation power is suggested as is sufficient heatsinking of the transducer whenever possible. For optimum stability a one hour warm-up is recommended. Avoid large temperature changes or stray magnetic fields.

The OM-2 bridgesensor is ready to wire into your system, have power applied, and start making measurements for you.

Load Cell Central
 P. O. Box 91 / 216 Main St.
 Monroeton, PA 18832
 Toll Free: 1-800-LOADCEL / 1-800-562-3235

TERMINAL STRIP ASSIGNMENTS			
1	-SENSE	8	+INPUT
2	B-	9	-INPUT
3	+SENSE	10	AMPLIFIER CMN
4	B+	11	AMPLIFIER OUTPUT
5	NOT USED	12	FILTER - C1
6	AC	13	FILTER - C2
7	AC		

PACKAGING

Specifically designed for rugged field use the OM-2 is completely encapsulated in epoxy using a vacuum potting system to insure a complete seal against corrosive environments. It is similarly protected against shock and vibration and will provide years of reliable and accurate operation.

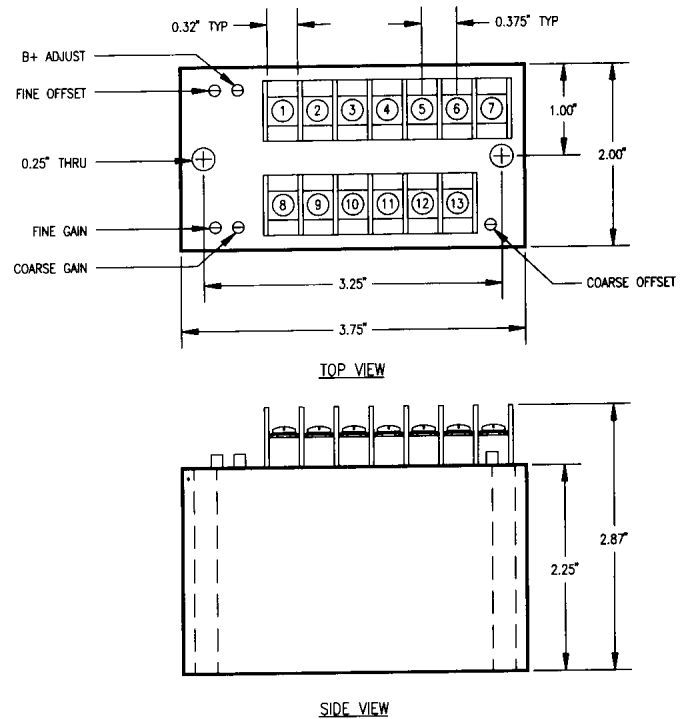

FIGURE 5. Case Dimension

Phone: 1-570-265-5015
 Fax: 1-570-265-5148
 Email: salesam@800loadcel.com
 Web: www.800loadcel.com