

Load Cell Central

1-800-LOADCEL

WN1 Single Point Platform Load Cell

Interchangeable with NCI/Weigh-Tronix* Mark 1 (MK-1)

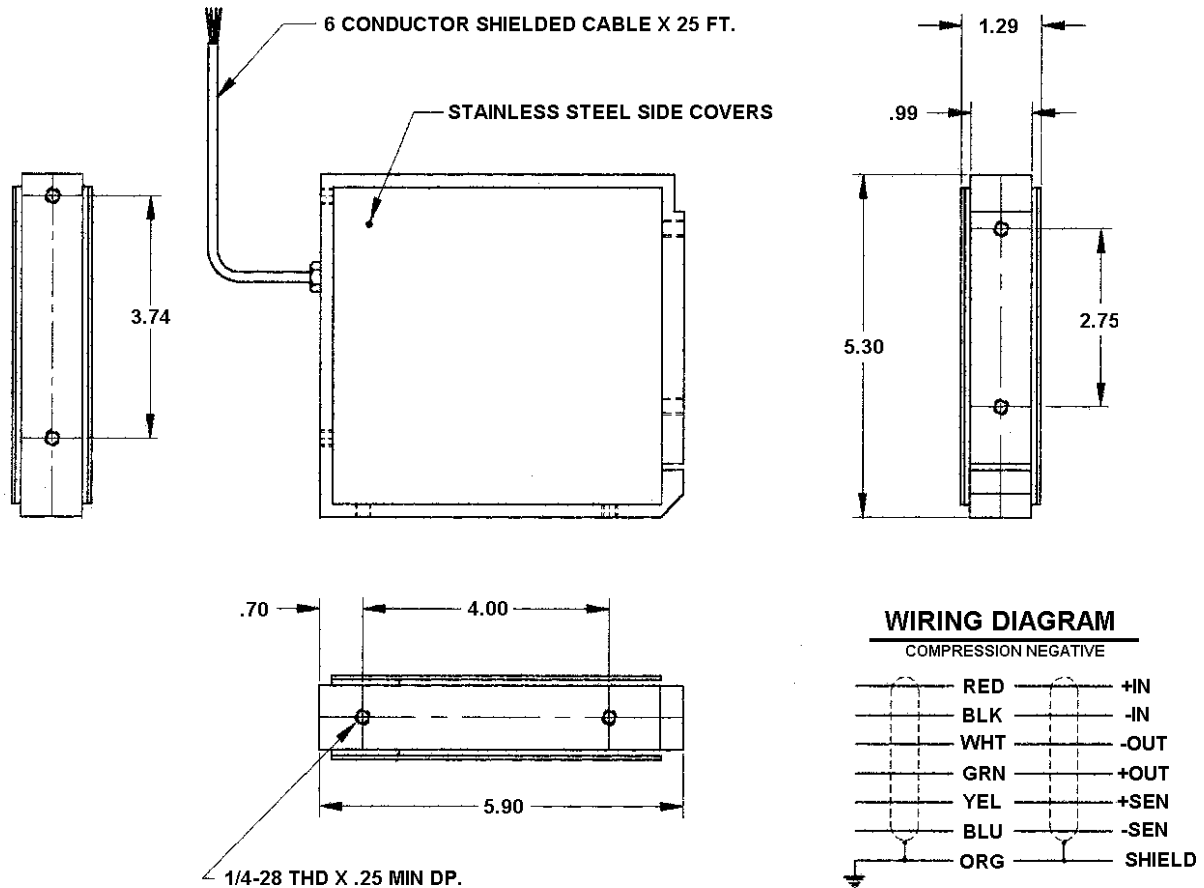

SPECIFICATIONS

CAPACITIES: 50, 100, 500, 1K, 2K, 3K lbs.

Moment Compensated

Output: 2 mV/V \pm 0.5%

Non-Linearity: .02% F.S.

Hysteresis: .02% F.S.

Creep (20 min): .01% F.S.

Material: Nickel Plated Alloy Steel

Comp. Temp. Range: 0 to 150°F

Temp Effect Span: .0007%/°F

Temp Effect Zero: .0013%/°F

Input Resistance: 400 ohms

Output Resistance: 350 ohms

Safe Overload: 200%

*trademark of Weigh-Tronix, Inc.

Load Cell Central follows a policy of continuous improvement and reserves the right to change specifications without notice. © 2008

Load Cell Central
216 Main St. / PO Box 91
Monroeton, PA 18832
Web: www.800loadcel.com

Toll Free: 1-800-562-3235
Ph: 1-570-265-5015
Fax: 1-570-265-5148
Email: sales@800loadcel.com